

Consistometer Model E

C.W. Brabender® Instruments Inc. introduces The New Consistometer Model E. The Consistometer E utilizes high precision torque cell technology to measure the viscosity of Newtonian and non-Newtonian materials.

Application

In the Food Industry the instrument is used to evaluate a wide range of materials for the laboratory, production and quality control. Its application can be used to measure apparent viscosity and perceived difference in the flow properties of fluids, pastes, slurries and semi-solids with particulates. It may be used to characterize the flow behavior of materials and to predict consistency, processing ability or stability. The Consistometer Model E offers a wide measurement range, from a few centipoises up to 700,000 centipoises. The unit offers a menu driven electronic keypad and display for ease of operation and observation of data. The robust, rugged design is well suited for the toughest production and/or laboratory environment.

Whether you use our standard bowl or your own specific product can --- the Consistometer E was designed for complete flexibility and will provide apparent viscosity measurements at room temperature. Optional equipment, such as water circulators and other accessories will allow you to investigate your product at fixed or programmed temperature rates to mimic actual process temperatures and conditions. The Consistometer has been a standard instrument in measuring thermal processing of cream styled corn, as well as baby food and chocolate for crystallization measurements. We invite you to share your applications so you can benefit from our 85 year of laboratory testing experience.

Brabender®
Consistometer
Model E



Best suited for applications/
materials such as:

- Cream-Style Corn
- Ketchup and Tomato Juice
- Baby Food
- Chocolate Crystallization
- Puddings, Custards and Pie Fillings
- Dough Batter
- Other Food Systems

The Brabender® Consistometer E -
An instrument engineered for your applications...

Brabender® Consistometer Model E

Specifications

Technical Data	
Accuracy:	0.5% fsd
Speed:*	78 RPM (fixed speed)
Digital Torque Display:	cm-g or BU
Digital Temperature Indication:	Optional (10°C to 150°C)
Dimensions:	14" x 15" x 30" (W x D x H)
Weight:	60 lbs
Power requirements:	120V, 60 Hz, Single Phase, 3 Amps

* Optional Variable Speed (20 - 250 RPM)

Principle Of Measurement

The Consistometer uses reaction torque for dynamic measurement. Reaction torque is developed by submersing a sensor element in a rotating sample vessel containing the test material and measuring the resultant torque expended by the material on the sensing device. The torque is measured in units of either Centimeter-grams (cm-g) or Brabender Units (BU). The measured torque, time and speed data can then be utilized to calculate the apparent viscosity and characterize the flow behavior of the test material.

Features

The unit is designed to meet a broad range of viscosity testing requirements. The new Model E design improves measurement range and precision, reduces operator error and offers unbiased results. Its new quick disconnect sensors facilitate easy clean up and changing of the sensors. Temperature can be measured and displayed via an optional Pt100 temperature probe. The instrument controls and measures speed at fixed intervals or may be programmed to interpret shear dependent flow behaviors with the protocol design and data transfer option.

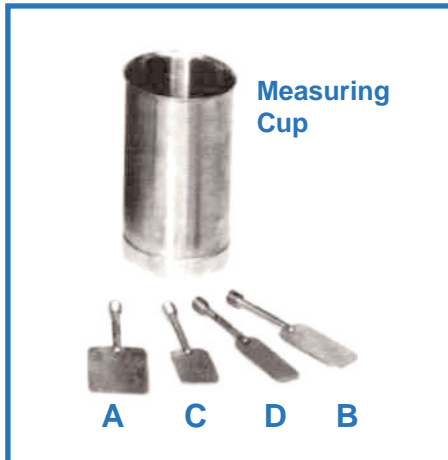

Interchangeable Sensors and Accessories:

Catalog #03-30-037	Paddle "A" (2" D x 1.4" W)
Catalog #03-30-038	Paddle "B" (2" D x 1" W)
Catalog #03-30-039	Paddle "C" (1.5" D x 1" W)
Catalog #03-30-040	Paddle "D" (2" D x 0.75" W)
Catalog #03-30-001	Measuring Cup
Catalog #03-33-004	Temperature Probe
Catalog #03-33-010	Calibration Kit
Catalog #	Custom Shipping and Storage Case
Catalog #	Protocol Design & Data Transfer Option

The New Consistometer Model E is:

- Value engineered and priced
- Utilizes high precision torque cell technology
- Offers a wide measurement range
- Is easy to operate, clean and maintain
- Controls and measures via a menu driven keypad and display
- Robust in design

Subject to changes of design and technical modifications without notice.

